

## Electrical Specifications

**Voltage:** 12 VDC  
**Duty Cycle:** Continuous  
**Resistance:** 27 ohms  $\pm$  10% (@ 20c)  
**Amps @ rated Volts:** 0.46  
**Watts @ rated Volts:** 5.5  
**Holding:** 170 lbs (1/4" Thick 1215 CRS @ 20c)  
**Operating Temp:** -40c to 60c (range)

## Additional Components

**Screw:** N/A  
**Spring:** N/A  
**Spiral Pin:** N/A  
**Potting:** United Resin Corp. (El-cast Black)

**Finish:** Housing - Zinc or Electroless Nickel Plating  
 (0.0002-0.0003")

Center Post Recessed  
 (.003-.005)  
 Quick Release

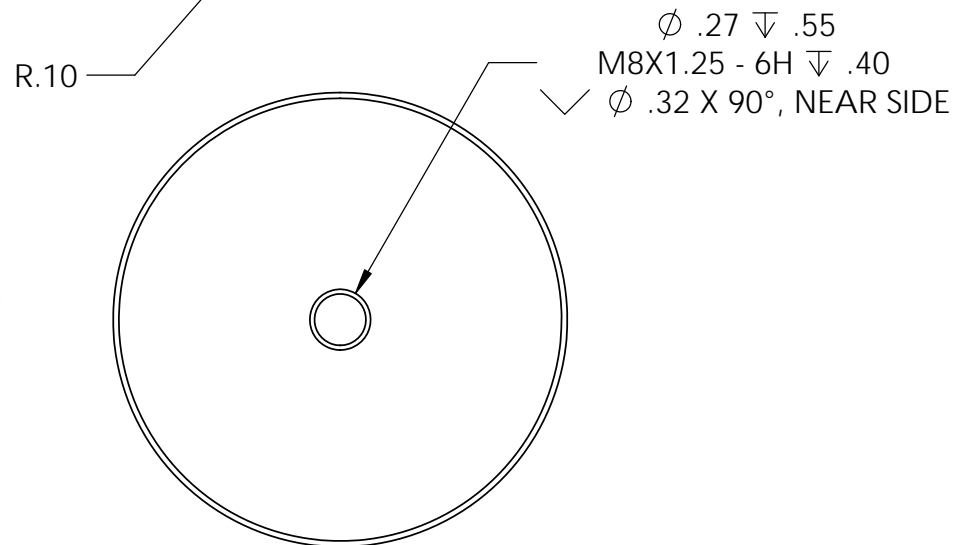
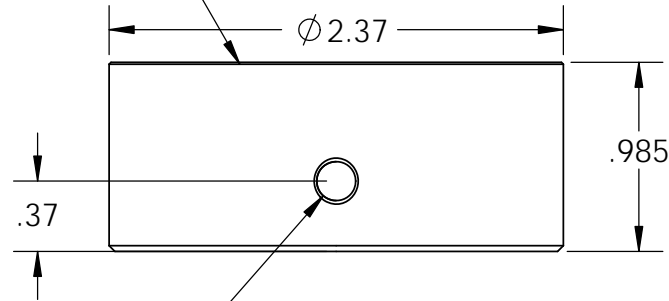

18" Long Leads  
 22 Ga. Teflon Type E

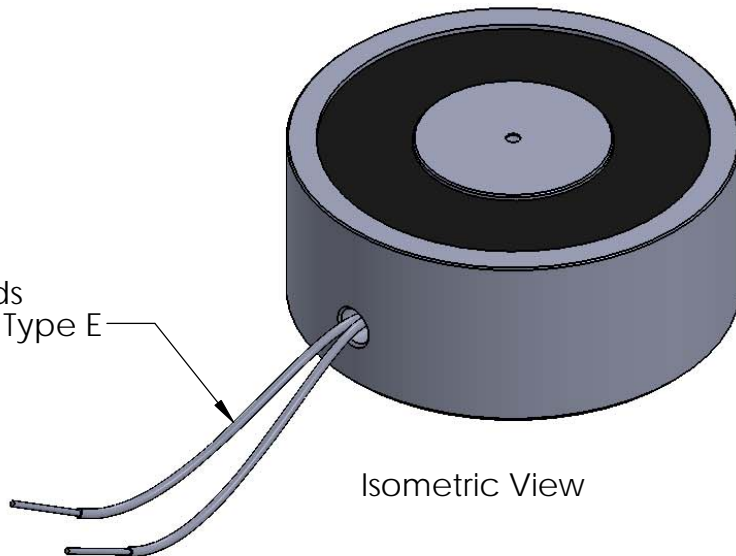

Isometric View

|             |  |  |  |                                 |      |                    |                                 |
|-------------|--|--|--|---------------------------------|------|--------------------|---------------------------------|
|             |  | UNLESS OTHERWISE SPECIFIED:  |  | NAME                            | DATE | <b>APW COMPANY</b> |                                 |
|             |  | DIMENSIONS ARE IN INCHES<br>TOLERANCES:<br>FRACTIONAL $\pm$ .015<br>ANGULAR: MACH $\pm$ 2 BEND $\pm$ 2<br>TWO PLACE DECIMAL $\pm$ .005<br>THREE PLACE DECIMAL $\pm$ .003 |  | DRAWN                           | K.H. |                    |                                 |
|             |  |  |  | CHECKED                         | J.K. | 06.27.11           | TITLE:<br><br>P/N: EM237-12-112 |
|             |  |  |  | ENG APPR.                       | J.K. | 06.27.11           |                                 |
|             |  |  |  | MFG APPR.                       | J.K. | 06.27.11           |                                 |
|             |  | INTERPRET GEOMETRIC TOLERANCING PER: ANSI  |  | Q.A.                            |      |                    | SIZE DWG. NO. REV               |
|             |  | MATERIAL   |  | COMMENTS:                       |      |                    |                                 |
| NEXT ASSY   |  | USED ON  |  |                                 |      |                    | FINISH                          |
| APPLICATION |  | DO NOT SCALE DRAWING   |  | SCALE: 1:2 WEIGHT: SHEET 1 OF 1 |      |                    |                                 |

**PROPRIETARY AND CONFIDENTIAL**  
 THE INFORMATION CONTAINED IN THIS DRAWING IS THE SOLE PROPERTY OF APW COMPANY. ANY REPRODUCTION IN PART OR AS A WHOLE WITHOUT THE WRITTEN PERMISSION OF APW COMPANY IS PROHIBITED.