

## Electrical Specifications

**Voltage:** 6 VDC  
**Duty Cycle:** Continuous  
**Resistance:** 5.1 ohms  $\pm$  10% (@ 20c)  
**Amps @ rated Volts:** 1.0  
**Watts @ rated Volts:** 6.0  
**Holding:** 100 lbs (1/4" Thick 1215 CRS @ 20c)  
**Operating Temp:** -40c to 60c (range)

## Additional Components

**Screw:** 1/4-20 x 1 1/4" Long (Hex Socket Head Cap) w/Nylok  
**Spring:** N/A  
**Spiral Pin:** N/A  
**Potting:** N/A  
  
**Finish:** Housing - Zinc or Electroless Nickel Plating  
 (0.0002-0.0003")

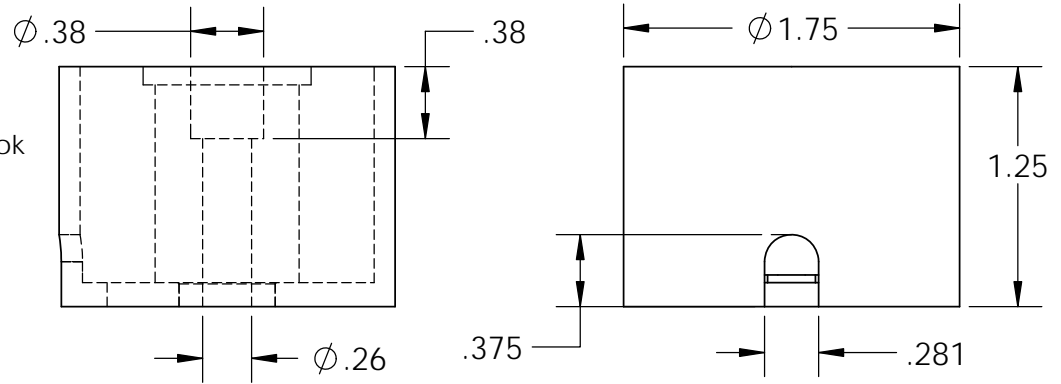

18" Long Leads  
 18 Ga. Type 1015 UL

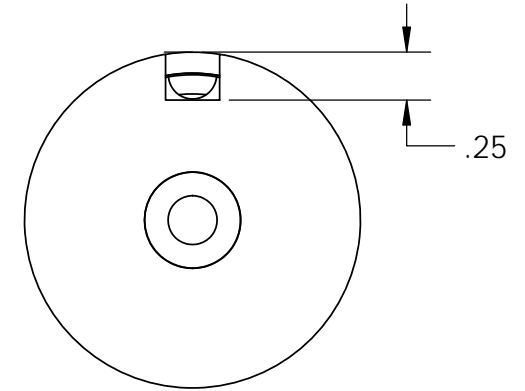
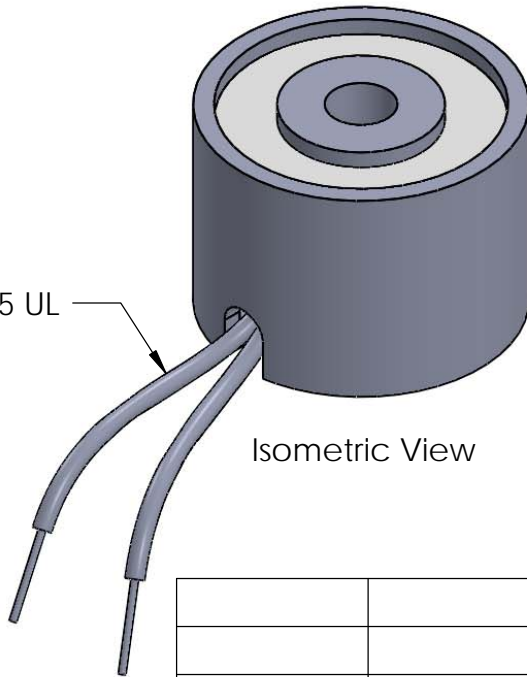

**PROPRIETARY AND CONFIDENTIAL**  
 THE INFORMATION CONTAINED IN THIS DRAWING IS THE SOLE PROPERTY OF APW COMPANY. ANY REPRODUCTION IN PART OR AS A WHOLE WITHOUT THE WRITTEN PERMISSION OF APW COMPANY IS PROHIBITED.

		UNLESS OTHERWISE SPECIFIED:	NAME	DATE
		DIMENSIONS ARE IN INCHES	DRAWN	K.H. 06.21.11
		TOLERANCES:	CHECKED	J.K. 06.21.11
		FRACTIONAL $\pm .015$	ENG APPR.	J.K. 06.21.11
		ANGULAR: MACH $\pm 2$ BEND $\pm 2$	MFG APPR.	J.K. 06.21.11
		TWO PLACE DECIMAL $\pm .005$	Q.A.	
		THREE PLACE DECIMAL $\pm .003$	COMMENTS:	
		INTERPRET GEOMETRIC TOLERANCING PER: ANSI		
		MATERIAL		
NEXT ASSY	USED ON	FINISH		
APPLICATION		DO NOT SCALE DRAWING		

<b>APW COMPANY</b>		
TITLE: P/N: EM175-6-222		
SIZE <b>A</b>	DWG. NO. <b>5757</b>	REV
SCALE: 1:1	WEIGHT:	SHEET 1 OF 1