

Electrical Specifications

Voltage: 6 VDC
Duty Cycle: Continuous
Resistance: 2.56 ohms \pm 10% (@ 20c)
Amps @ rated Volts: 2.50
Watts @ rated Volts: 15.0
Holding: 300 lbs (1/4" Thick 1215 CRS @ 20c)
Operating Temp: -40c to 60c (range)

Additional Components

Screw: 5/16-18 x 1 1/2" Long (Socket Head Cap Screw) w/Nylok
Spring: N/A
Spiral Pin: N/A
Potting: United Resin Corp. (EI-cast Black)
Finish: Housing - Zinc or Electroless Nickel Plating (0.0002-0.0003")

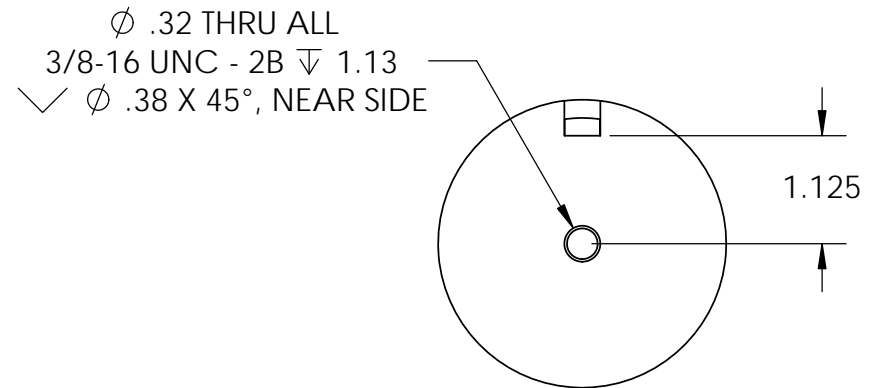
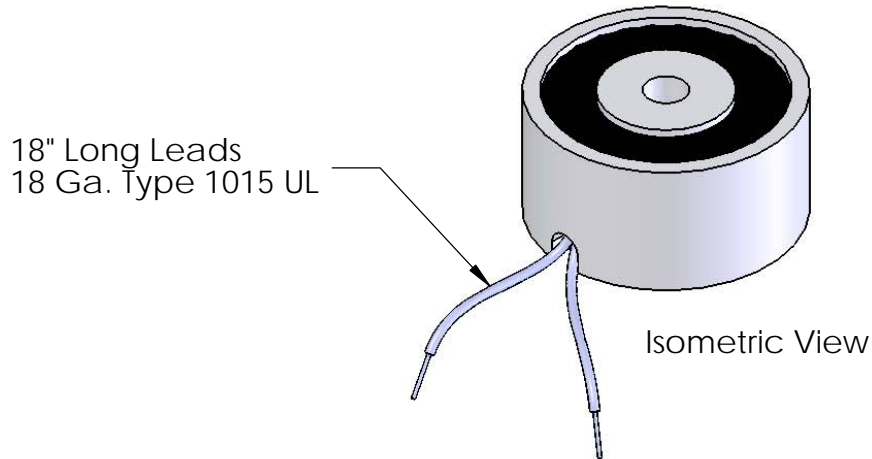
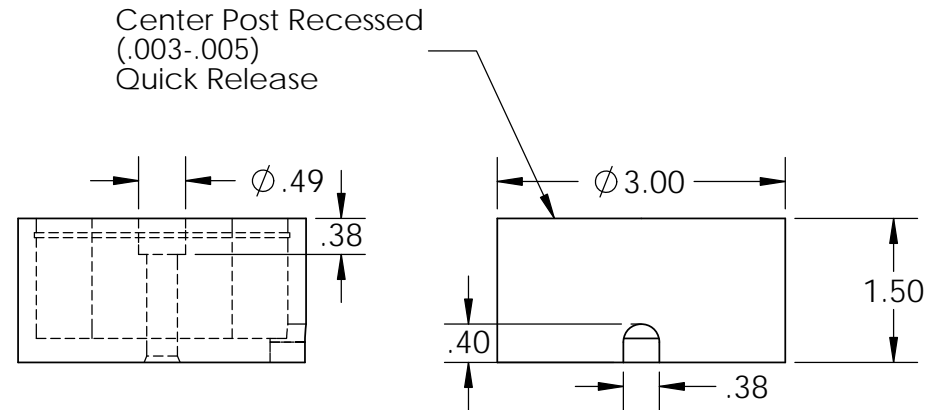

PROPRIETARY AND CONFIDENTIAL
 THE INFORMATION CONTAINED IN THIS DRAWING IS THE SOLE PROPERTY OF APW COMPANY. ANY REPRODUCTION IN PART OR AS A WHOLE WITHOUT THE WRITTEN PERMISSION OF APW COMPANY IS PROHIBITED.

		UNLESS OTHERWISE SPECIFIED:			APW COMPANY	
		DIMENSIONS ARE IN INCHES	DRAWN	K.H.	07.15.11	TITLE: P/N: EM300-6-112
		TOLERANCES:	CHECKED	J.K.	07.15.11	
		FRACTIONAL \pm .015	ENG APPR.	J.K.	07.15.11	
		ANGULAR: MACH \pm 2 BEND \pm 2	MFG APPR.	J.K.	07.15.11	
		TWO PLACE DECIMAL \pm .005	Q.A.			SIZE DWG. NO. REV A 5552
		THREE PLACE DECIMAL \pm .003	COMMENTS:			
		INTERPRET GEOMETRIC TOLERANCING PER: ANSI				SCALE: 1:2 WEIGHT: SHEET 1 OF 1
		MATERIAL				
		FINISH				
NEXT ASSY	USED ON					
APPLICATION		DO NOT SCALE DRAWING				